

## PRODUCT SPECIFICATION

<b>Product Code</b>	<b>8800E</b>
<b>Description</b>	<b>WHITE PIBA FOR ENFIT TIPS FOR BOTTLE NECKS ID 18-22MM (Box of 100)</b>

<b>Contract Manufacturer</b>	Micsafe Medical Group 6-722 Oasis Middle Ring Centre No. 1678 Jinshajiang Road Shanghai 200333 China <b>At manufacturing site:</b> Jiangsu Micsafe Medical Technology Co.,Ltd Xituan Industrial Park, Dafeng District, Yancheng City, Jiangsu Province, China	A022
<b>Legal manufacturer/ CE mark holder</b>	Miktell Ltd, Aston Court, Kingsmead Business Park, Frederick Place, High Wycombe HP11 1JU UK	
<b>EC Rep</b>	Emergo Europe, Prinsessegracht 20 2514AP The Hague The Netherlands	

### Product Specification

Classification	Class 1 medical device		
Material	UL814 PE		
Colour	White		
UDI	05060386541257		
Box of 100	8800E	UDI	35060386541258
Bag of 1000	8800E1000	UDI	45060386541255
Box of 10,0000	10*8800E1000	UDI	15060386541254
Method of sterility	Supplied non-sterile		
Shelf Life	5 years from manufacture		

### References and norms

	Reference
To fit internal bottle neck dimensions 18-22mm.	
For use with Enfit syringe tips	ISO80369-3
Material Specification	UL814 General information sheet
Material Test Report	UL814_EC Test Report
Biological Evaluation Report to ISO 10993-1:2009	Miktell Ltd – ENFIT Syringe Medicine Bottle Adapter Version 1.0 – 12 September 2018 (author: Patient Guard)

### Packaging

8800E	Single bagged, tumble filled, in box of 100.
8800E1000	Double bagged, tumble filled, in bag of 1000.





### Storage and Handling Requirements

No Specific storage or handling conditions.





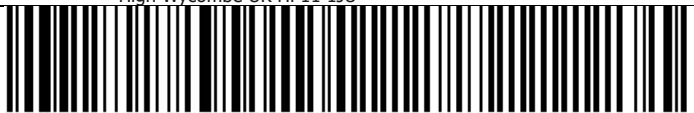

### Labelling

In accordance with ISO 15223-1







8800E Label Reference QFM147

	<b>MIKTELL</b>		QFM147 Rev D
<b>Press In Bottle Adaptor (PIBA) for Enfit tip syringes (White) to fit bottle neck 18-22mm</b>			
REF	<b>8800E</b>	LOT	XXXXXXXX
		QTY	<b>100</b>
	YYYY-MM		YYYY-MM
			<b>MD</b> Medical Device
	Miktell Ltd, Aston Court Kingsmead Business Park, Frederick Place High Wycombe UK HP11 1JU	<b>EC</b>	<b>REP</b> EMERGO EUROPE Prinsessegracht 20 2514 AP The Hague The Netherlands
 (01) 35060386541258 (17) 010111 (10) 00000000			

8800E1000 Label Reference QFM187

	<b>MIKTELL</b>		QFM187Re v B
<b>Press In Bottle Adaptor (PIBA) for Enfit tip syringes (White) to fit bottle neck 18-22mm</b>			
REF	<b>8800E1000</b>	LOT	XXXXXXXX X
		QTY	<b>1000</b>
	YYYY-MM		YYYY-MM
			<b>MD</b> Medical Device
	Miktell Ltd, Aston Court Kingsmead Business Park, Frederick Place High Wycombe UK HP11 1JU	<b>EC</b>	<b>REP</b> EMERGO EUROPE Prinsessegracht 20 2514 AP The Hague The Netherlands
 (01) 45060386541255 (17) 010111 (10) 00000000			

8800E1000 box of 10 bags Label Reference QFM174

	<b>MIKTELL</b>			QFM188Rev B
<b>Press In Bottle Adaptor (PIBA) for Enfit tip syringes (White) to fit bottle neck 18-22mm</b>				
<b>REF</b>	<b>8800E1000</b>	<b>LOT</b>	<b>XXXXXXXX</b>	<b>QTY</b> <b>10 BAGS OF 1000</b>
	<b>YYYY-MM</b>		<b>YYYY-MM</b>	<b>MD</b> <small>Medical Device</small>
	Miktell Ltd, Aston Court Kingsmead Business Park, Frederick Place High Wycombe UK HP11 1JU	<b>EC</b>	<b>REP</b>	<b>EMERGO EUROPE</b> Prinsessegracht 20 2514 AP The Hague The Netherlands
 (01) 55060386541252 (17) 010111 (10) 00000000				

**Product Drawing**

Micsafe drawing reference: MIC-MIK-CP-BS-001

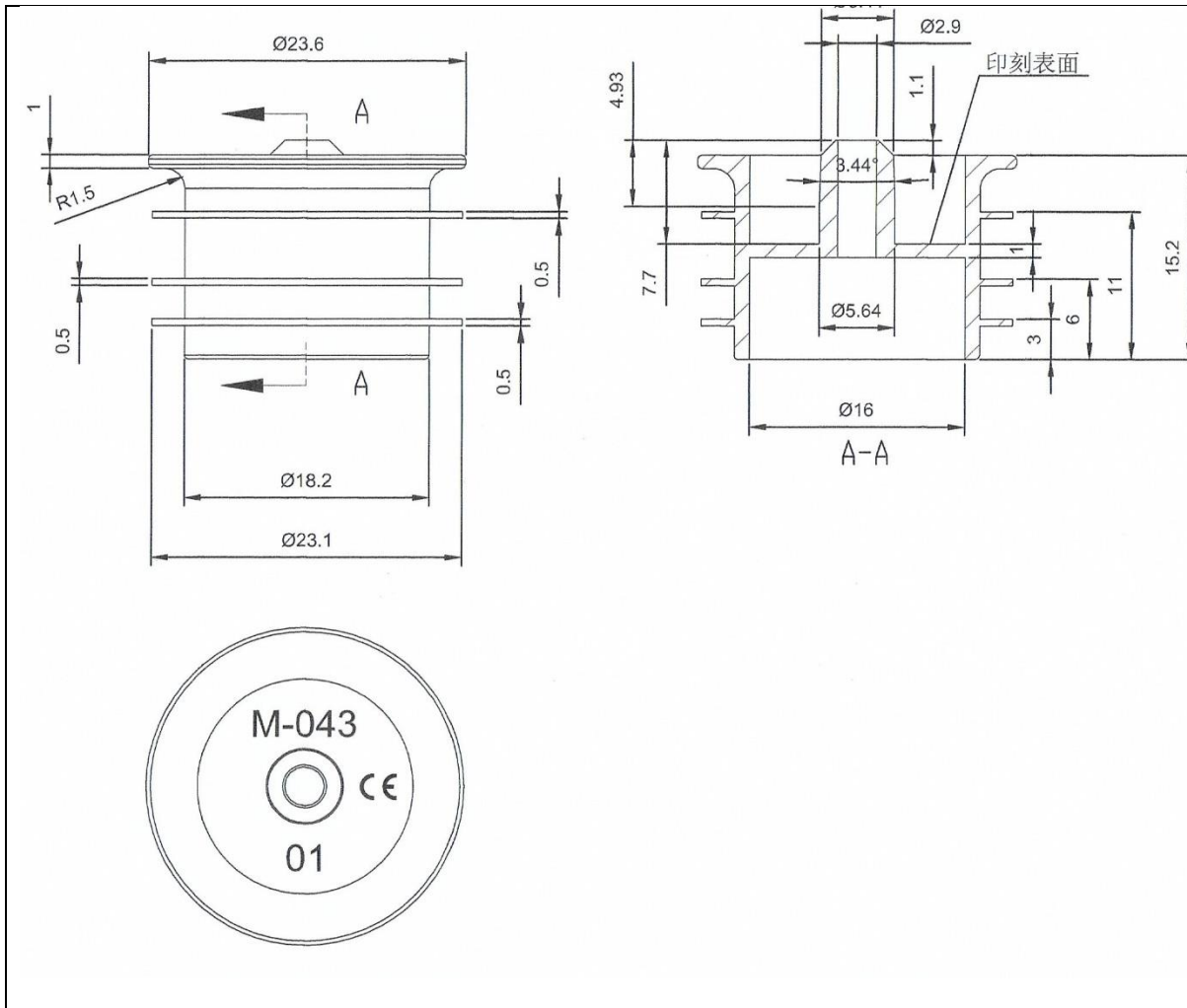
**Technical Requirements:**

1. Product surface must not have burrs, bubbles, defects or plastic flow defects
2. Product Surface should be clean, no discolouration or foreign matter
3. Rounded corners not marked R0.3
4. In addition to the special dimensioning on the surface of the tolerance, if the size is less than 10mm tolerance is 0.05mm, greater than or equal to 10mm tolerance of 0.1mm